

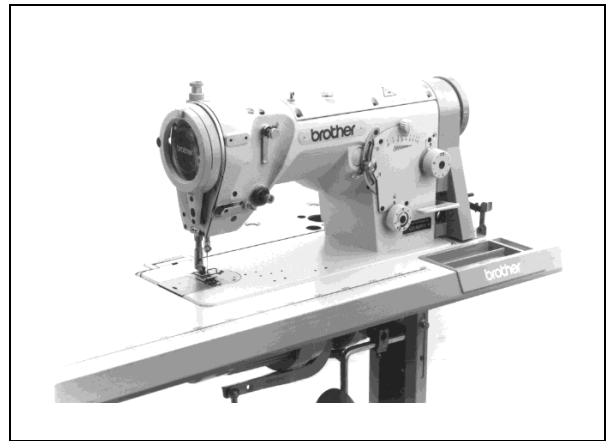





ZM-850A

ZM-851A

Single Needle Zigzag Lock Stitcher

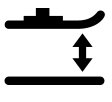
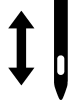

Specifications

						
	Zigzag stitch	1 - needle	Bottom feed	Height of Presser foot	Needle stroke	Max. sewing speed
ZM-850A	Zigzag width 5 mm	*	*	Manual 6 mm Knee 10 mm	33.3 mm	5,000 rpm
ZM-850A	Zigzag width 8 mm	*	*			
ZM-851A		*	*			

	ZM-850A - 1, ZM-851A - 1 (Foundation)	ZM-850A - 3 (Long stitch)
Max. stitch length	2.5 mm	5 mm
Thread take up	Rotary	
Presser pressure	20 - 60 N	
Needle type	SCHMETS SY1965 Nm70(#10)	
Hight of feed dog	1 mm	
Arm pocket area	W269 × D178 mm	

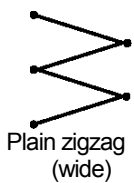

ZM-850A-00

	Use	Max. zigzag width
1	General (foundation)	5 mm
	Max. stitch length: 2.5 mm	8 mm
3	General (long stitch) Max. stitch length: 5mm	8 mm



ZM-851A-00

	Use	Max. zigzag width
1	General (foundation) Max. stitch length: 2.5 mm	8 mm

Gauge parts list

Zigzag width	Needle plate	Presser foot assy	Feed dog	
8 mm	<p>S48064-001</p>	<p>S48293-001</p>	<p>S48145-101 For long stitch feed</p>	
	<p>S48065-001</p>	<p>S48299-001</p>		
		<p>S48305-001</p>	<p>S48143-101 For long stitch feed</p>	
		<p>S58950-001 With tape guide</p>	<p>S52435-001 For general 3-step zigzag</p>	
			<p>S58908-001</p>	<p>S58908-001</p>
		<p>S54922-001</p>		<p>S52436-001 Good for sewing smoothly at sewing start and overlapping sections</p>
			<p>S54933-001 Good for sewing requiring frequent change of base line</p>	

*The presser feet with chamfering (S48299-001, S48305-001) are suitable for long stitch feed sewing.

Gauge parts list

Zigzag width	Needle plate	Presser foot assy	Feed dog
5 mm	<p>S06166-001</p>	<p>S48308-001</p>	<p>S52068-001</p> <p>For general plain zigzag</p>
	<p>S53410-001</p>		<p>S54937-001</p> <p>For sewing light material</p>
3 mm	<p>S48066-001</p>		<p>S06171-101</p>
	<p>S48067-001</p>		
3 mm	<p>S54929-001</p>	<p>S54956-001</p>	<p>S54945-001</p> <p>For sewing tape, hook, and edge of bra</p>
	<p>S54930-001</p>	<p>S54957-001</p>	<p>S54946-001</p> <p>For sewing tape, hook, and edge of bra</p>

Option parts
Separate type presser bar.

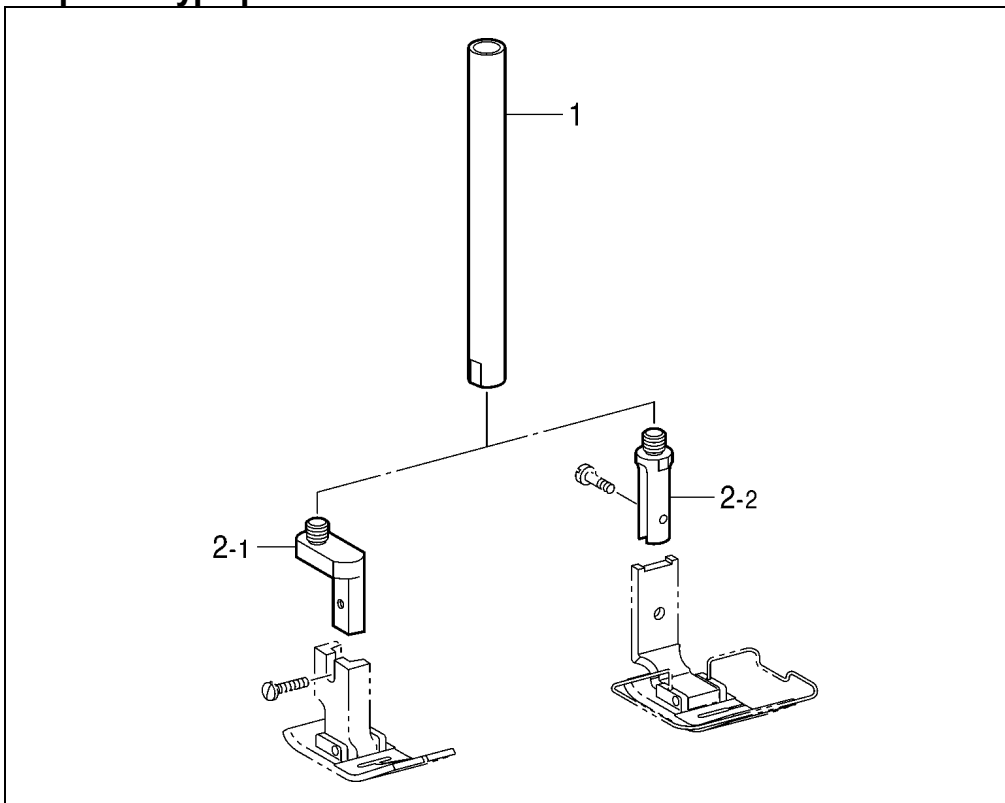

Ref. No.	Part name	Part code	Q'ty
1	Presser bar, U < For presser foots for lock stitch >	S50114-001	1
2-1	Presser bar tip, A < For standard presser foots >	S50115-001	1
2-2	Presser bar tip, B	S50116-001	1

Thread tension assy (disc type)

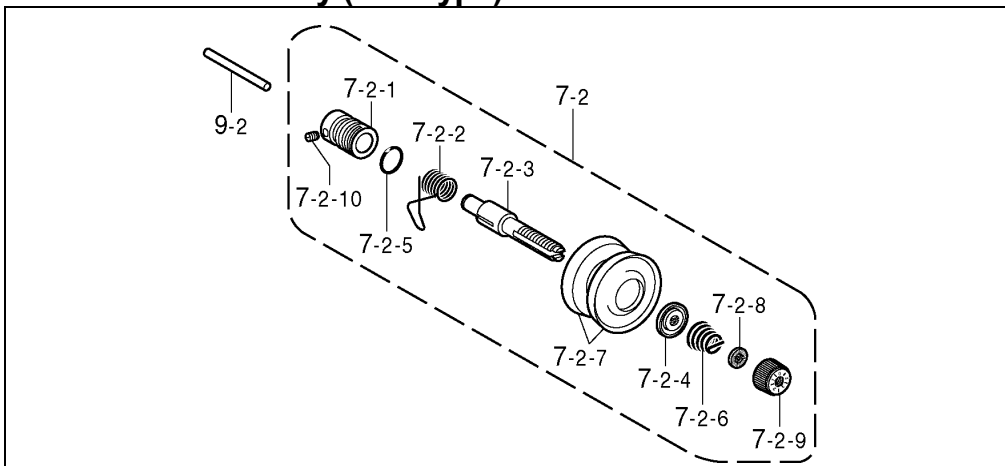

Ref. No.	Part name	Part code	Q'ty
7-2	Thread tension assy	S51808-001	1
7-2-1	Thread tension bracket	S48084-001	1
7-2-2	Thread take-up spring	S02620-001	1
7-2-3	Tension stud	116922-001	1
7-2-4	Disc presser, ;Tension	159805-001	1
7-2-5	O ring, S14	081014-870	1
7-2-6	Spring, tension ;M	104525-001	1
7-2-7	Disc, ;Tension	145446-001	2
7-2-8	Washer	S12441-001	1
7-2-9	Tension nut	S31032-001	1
7-2-10	Set screw, SM3.57	100402-004	1
9-2	Tension release pin	S51809-000	1

Thread guide, F / Felt

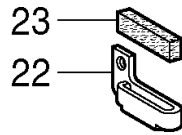

Ref. No.	Part name	Part code	Q'ty
22	Thread guide, F	S51814-001	1
23	Felt	114941-001	1

Rotary hook

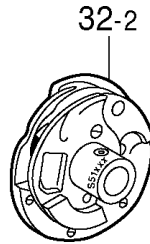

Ref. No.	Part name	Part code	Q'ty
32-2	Rotary hook assy, HP w/box (carbide reinforced hook tip)	S51821-901	1
32-2	Rotary hook assy w/box ;ST (for medium-weight materials)	S55026-901	1

Thread take-up

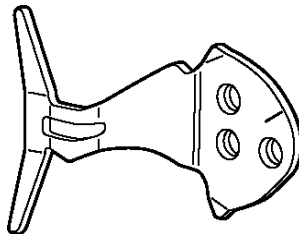

Part name	Part code	Q'ty
Rotary thread take-up lever (for plain zigzag and tape attaching)	S54996-001	1